

# aurea

Aurea nasce dalla brillante intuizione di utilizzare la Sezione Aurea per la definizione delle proporzioni del disegno dell'anta, per realizzare un prodotto esclusivo, dall'armoniosa classicità. Il modello Aurea viene declinato in tre tipologie di Stili diversi: lo stile NEW FOLK, il CONTEMPORANEO e il CLASSICO, tutti caratterizzati da elementi e accessori appositamente studiati da Creo Kitchens. Una completa gamma di prestigiose finiture come il Rovere Naturale con Nodini o il Frassino laccato Bianco a Poro Aperto, il color Corda Decapé o nella raffinata tinta Noce Spazzolato. Con il programma Aurea, si possono realizzare composizioni per ambienti di ogni dimensione e tipologia, personalizzandoli e rendendoli emozionalmente unici.



Aurea arises from the brilliant intuition to use the Aurea Section to define proportions of the door design, to create an exclusive product, with a harmonious classicism. Aurea model is available in three different styles: the NEW FOLK, the CONTEMPORARY and the CLASSIC one, all characterized by items and accessories specifically designed by Creo Kitchens. A full range of elegant finishes such as the Knotted Natural Oak or the White Lacquered Ash Open Pore, the color Pickled Cord or the Brushed Walnut. The Aurea program allows to create compositions for all kinds of environments, customizing and making them emotionally unique.



## CREO ECOLOGIC

IL GRUPPO LUBE HA SCELTO DI UTILIZZARE PER I COMPONENTI COSTITUENTI LE STRUTTURE DELLE CUCINE SOLO MATERIALE A BASSISSIMA EMISSIONE DI FORMALDEIDE: CONFORMI ALLO STANDARD F4STELLE SECONDO LA NORMA JIS, CERTIFICATO DAL MINISTERO GIAPPONESE, IL PIÙ SEVERO IN MERITO ALLE NORMATIVE DI SALVAGUARDIA AMBIENTALE.

LUBE GROUP HAS CHOSEN TO EXCLUSIVELY USE MATERIALS WITH VERY LOW FORMALDEHYDE EMISSIONS FOR THE COMPONENTS MAKING UP THE KITCHEN CARCASSES: THESE ELEMENTS COMPLY WITH THE F4 STAR STANDARD ACCORDING TO JIS, CERTIFIED BY THE JAPANESE GOVERNMENT - THE MOST STRINGENT WHEN IT COMES TO ENVIRONMENTAL PROTECTION.

N.B.: i prezzi sono espressi all'unità di euro (iva esclusa)

## CARATTERISTICHE TECNICHE

ANTE	<p>intelaiata sp.22 mm in massello di frassino con bugna impiallacciato frassino nei colori: laccato bianco a poro aperto (opz.2451), tinto corda decapè (opz.2452), tinto noce spazzolato (opz.2453)</p> <p>intelaiata sp.22 mm in massello di rovere naturale con nodini (opz.5501), bugna impiallacciato rovere naturale</p>
ANTE CON BUGNA MAGNETICA EFFETTO LAVAGNA	<p>disponibili nelle misure 71,7x44,7 - 71,7x59,7 - 35,7x44,7 - 35,7x59,7 - 35,7x89,7 - 47,7x59,7 - 47,7x89,7 - 131,7x44,7 - 131,7x59,7 nei colori: laccato bianco a poro aperto (opz.2451L), tinto corda decapè (opz.2452L), rovere naturale con nodini (opz.5501L)</p>
ANTE CON INTARSIO	<p>disponibili nelle misure 71,7x44,7 - 71,7x59,7 - 35,7x44,7 - 35,7x59,7 - 35,7x89,7 nei colori: laccato bianco a poro aperto (opz.2451D), tinto corda decapè (opz.2452D), tinto noce spazzolato (opz.2453D), rovere naturale con nodini (opz.5501D)</p>
ANTE CON DECORO METALLICO	<p>disponibili nelle misure 71,7x44,7 - 71,7x59,7 - 35,7x44,7 - 35,7x59,7 - 35,7x89,7 - 95,7x44,7 - 95,7x59,7 - 131,7x59,7 nei colori: laccato bianco a poro aperto (opz.2451M), tinto corda decapè (opz.2452M), rovere naturale con nodini (opz.5501M), con placchetta in metallo finitura canna di fucile spazzolato</p>
FRONTALI CASSETTI	<p>in massello di frassino nei colori: laccato bianco a poro aperto (opz.2451), tinto corda decapè (opz.2452), tinto noce spazzolato (opz.2453)</p> <p>in massello di rovere naturale con nodini (opz.5501)</p>
ANTE VETRO di serie	<p>VETRO SATINATO BIANCO SP.4 MM FILO GREZZO, TEMPERATO, DUE LATI VERTICALI SERIGRAFATI BIS.23, INCISO LUCIDO LATO SATINATO</p> <p>telaio sp.22 mm in massello di frassino nelle finiture: laccato bianco a poro aperto (opz.2451S), corda decapè (opz.2452S), tinto noce spazzolato (opz.2453S)</p> <p>telaio sp.22 mm in massello di rovere naturale con nodini (opz.5501S)</p>
a richiesta	<p>VETRO TRASPARENTE SP.4 MM FILO GREZZO, TEMPERATO, SERIGRAFATO EFFETTO TESSUTO IN VERNICE COLORE BIANCO, TELAIO INGLESINA</p> <p>telaio sp.22 mm in massello di frassino con bugna impiallacciato frassino nei colori: laccato bianco a poro aperto (opz.2451I), corda decapè (opz.2452I), tinto noce spazzolato (opz.2453I)</p> <p>telaio sp.22 mm in massello di rovere naturale con nodini (opz.5501I)</p>
MANIGLIE	<p><b>di serie:</b> 200 finitura argento antico passo mm 128 per anta L 15 pomo 200P finitura argento antico</p> <p><b>a richiesta:</b> 240 finitura canna di fucile spazzolato passo mm 160 per anta L 15 pomo 240P finitura canna di fucile spazzolato</p> <p>236 finitura cromo passo mm 128 per anta L 15 pomo 244P pomo finitura cromo</p> <p>185 finitura ottone vecchio chiaro passo mm 96</p> <p>172 finitura argento vecchio brillante passo mm 96</p> <p>241 finitura cromo satinato passo mm 64/160 in funzione dell'anta</p>
STRUTTURE	<p><b>ANTA: laccato bianco a poro aperto</b> nobilitato bianco camelia (opz.606), schiena e ripiano bianco (opz.001)</p> <p><b>ANTA: tinto corda decapè</b> nobilitato corda decapè (opz.566), schiena e ripiano bianco (opz.001)</p> <p><b>ANTA: tinto noce spazzolato</b> nobilitato castagno tinto noce (opz.582), schiena e ripiano bianco (opz.001)</p> <p><b>ANTA: rovere naturale con nodini</b> nobilitato rovere sbiancato (opz.025), schiena e ripiano bianco (opz.001)</p>
MENSOLE	<p><b>di serie:</b> altezza 3,8 cm in laminato, bianco camelia (opz.606), corda decapè (opz.566) castagno tinto noce (opz.582), rovere sbiancato (opz.025)</p> <p><b>a richiesta:</b> altezza 3,8 cm impiallacciate finiture come ante</p>
ZOCCOLI	<p><b>di serie:</b> altezza 15 cm in pvc ricoperti in melamina nei colori: laccato bianco (opz.569), corda decapè (opz.566), castagno tinto noce (opz.582), rovere naturale (opz.5501)</p> <p><b>a richiesta:</b> altezza 15 cm in alluminio liscio finitura brill (opz.412), vedi maggiorazione pag.15</p>



Note: the prices are expressed in units of euro (vat excluded)

## TECHNICAL FEATURES

<b>DOORS</b>	<p>22-mm thick frame in solid ash with ash veneered raised panel in the following colours: white lacquered open pore (opt.2451), stained pickled jute (opt.2452), walnut stained brushed (opt.2453)</p> <p>22-mm thick frame in natural oak with knots (opt.5501), natural oak veneered raised panel</p>
<b>DOOR WITH RAISED PANEL MAGNETIC EFFECT BLACKBOARD</b>	<p>available in the following sizes 71.7x44.7 - 71.7x59.7 - 35.7x44.7 - 35.7x59.7 - 35.7x89.7 - 47.7x59.7 - 47.7x89.7 - 131.7x44.7 - 131.7x59.7 and in the following colours: white lacquered open pore (opt.2451L), stained pickled jute (opt.2452L), natural oak with knots (opt.5501L)</p>
<b>DOOR WITH INLAYD</b>	<p>available in the following sizes 71.7x44.7 - 71.7x59.7 - 35.7x44.7 - 35.7x59.7 - 35.7x89.7 and in the following colours: white lacquered open pore (opt.2451D), stained pickled jute (opt.2452D), walnut stained brushed (opt.2453D), natural oak with knots (opt.5501D)</p>
<b>DOOR WITH METALLIC DECOR</b>	<p>available in the following sizes 71.7x44.7 - 71.7x59.7 - 35.7x44.7 - 35.7x59.7 - 35.7x89.7 - 95.7x44.7 - 95.7x59.7 - 131.7x59.7 and in the following colours: white lacquered open pore (opt.2451M), stained pickled jute (opt.2452M), natural oak with knots (opt.5501M), with metal plate brushed gunmetal finish</p>
<b>DRAWER FRONT PANELS</b>	<p>in solid ash in the following colours: white lacquered open pore (opt.2451), stained pickled jute (opt.2452), walnut stained brushed (opt.2453)</p> <p>in solid natural oak with knots (opt.5501)</p>
<b>GLASS DOORS standard</b>	<p>WHITE FROSTED-FINISH GLASS 4-MM THICK NATURAL BEVEL, TOUGHENED, TWO SCREEN-PRINTED VERTICAL SIDES BIS.23, HIGH-SHEEN ETCHING FROSTED-FINISH SIDE</p> <p>22-mm thick solid ash frame in the following finishes: white lacquered open pore (opt.2451S), pickled jute (opt.2452S), walnut stained brushed (opt.2453S)</p> <p>22-mm thick frame in natural oak with knots (opt.5501S)</p>
<b>on request</b>	<p>4-MM THICK CLEAR GLASS, NATURAL BEVEL, TOUGHENED, HIGH-GLOSS FABRIC-EFFECT SILK-SCREENPRINT WHITE, FRAME WITH MULLION ACCENTS</p> <p>22-mm thick frame in solid ash with raised panel in veneered ash in the following colours: white lacquered open pore (opt.2451I), pickled jute (opt.2452I), walnut stained brushed (opt.2453I)</p> <p>22-mm thick frame in natural oak with knots (opt.5501I)</p>
<b>HANDLES</b>	<p><b>standard:</b> 200 antique silver finish, 128 mm centre-to-centre distance for door W 15 antique silver finish knob hole 200P</p> <p><b>on request:</b> 240 brushed gunmetal finish, 160 mm centre-to-centre distance for door W 15 brushed gunmetal finish knob hole 240P</p> <p>236 chrome finish, 128 mm centre-to-centre distance for door W 15 chrome-finish knob hole 244P</p> <p>185 with light old brass finish, 96 mm centre-to-centre distance</p> <p>172 in polished old silver finish, 96 mm centre-to-centre distance</p> <p>241 satin chrome finish, 64/160 mm centre-to-centre distance depending on the door</p>
<b>STRUCTURES</b>	<p><b>DOOR: white lacquered open pore</b> melamine-coated camellia white (opt.606), white back panel and shelf (opt.001)</p> <p><b>DOOR: stained pickled jute</b> melamine-coated pickled jute (opt.566), white back panel and shelf (opt.001)</p> <p><b>DOOR: walnut stained brushed</b> melamine-coated walnut-stained chestnut (opt.582), white back panel and shelf (opt.001)</p> <p><b>DOOR: natural oak with knots</b> melamine coated bleached oak (opt.025), white back panel and shelf (opt.001)</p>
<b>SHELVES</b>	<p><b>standard:</b> height 3.8 cm in laminated wood, camellia white (opt.606), pickled jute (opt.566) walnut-stained chestnut (opt.582), bleached oak (opt.025)</p> <p><b>on request:</b> height 3.8 cm, veneered with same finishes as doors</p>
<b>PLINTHS</b>	<p><b>standard:</b> height 15 cm in PVC coated with melamine in the following colours: lacquered white (opt.569), pickled jute (opt.566), walnut-stained chestnut (opt.582), natural oak (opt.5501)</p> <p><b>on request:</b> height 15 cm, smooth aluminium with brill finish (opt.412), see surcharges on page 15</p>



cod. **K70** SP. 22 MM

*aurea*

ante in frassino laccate bianche a poro aperto  
white lacquered ash doors open pore



anta (opz.2451)  
door (opt.2451)



anta con intarsio  
(opz.2451D)  
door with inlayd  
(opt.2451D)



anta con decoro metallico  
(opz.2451M)  
door with metallic decor  
(opt.2451M)



anta con lavagna magnetica  
(opz.2451L)  
door with magnetic blackboard  
(opt.2451L)

 *colori in pronta consegna  
available colours*

cassetto e cestoni in frassino laccato bianco a poro aperto  
white lacquered ash drawer and deep drawers open pore



cassetto (opz.2451)  
drawer (opt.2451)



cestone (opz.2451)  
deep drawer (opt.2451)



cestone con intarsio  
(opz.2451D)  
deep drawer with inlayd  
(opt.2451D)



cestone con decoro  
metallico (opz.2451M)  
deep drawer with metallic  
decor (opt.2451M)

ante in rovere naturale con nodini  
natural oak with knots doors



anta (opz.5501)  
door (opt.5501)



anta con intarsio  
(opz.5501D)  
door with inlayd  
(opt.5501D)



anta con decoro metallico  
(opz.5501M)  
door with metallic decor  
(opt.5501M)



anta con lavagna magnetica  
(opz.5501L)  
door with magnetic blackboard  
(opt.5501L)

 *colori in pronta consegna  
available colours*

cassetto e cestoni in rovere naturale con nodini  
natural oak with knots drawer and deep drawers



cassetto (opz.5501)  
drawer (opt.5501)



cestone (opz.5501)  
deep drawer (opt.5501)



cestone con intarsio  
(opz.5501D)  
deep drawer with inlayd  
(opt.5501D)



cestone con decoro  
metallico (opz.5501M)  
deep drawer with metallic  
decor (opt.5501M)

cod. **K70** SP. 22 MM

*aurea*

ante in frassino tinto corda decapè  
pickled jute ash doors



anta (opz.2452)  
door (opt.2452)



anta con intarsio  
(opz.2452D)  
door with inlayd  
(opt.2452D)



anta con decoro metallico  
(opz.2452M)  
door with metallic decor  
(opt.2452M)



anta con lavagna magnetica  
(opz.2452L)  
door with magnetic blackboard  
(opt.2452L)

cassetto e cestoni in frassino tinto corda decapè  
pickled jute ash drawer and deep drawers



cassetto (opz.2452)  
drawer (opt.2452)



cestone (opz.2452)  
deep drawer (opt.2452)



cestone con intarsio  
(opz.2452D)  
deep drawer with inlayd  
(opt.2452D)



cestone con decoro  
metallico (opz.2452M)  
deep drawer with metallic  
decor (opt.2452M)

ante in frassino tinto noce spazzolato  
walnut stained brushed ash doors



anta (opz.2453)  
door (opt.2453)



anta con intarsio  
(opz.2453D)  
door with inlayd  
(opt.2453D)

cassetto e cestoni in frassino tinto noce spazzolato  
walnut stained brushed ash drawer and deep drawers



cassetto (opz.2453)  
drawer (opt.2453)



cestone (opz.2453)  
deep drawer (opt.2453)



cestone con intarsio  
(opz.2453D)  
deep drawer with inlayd  
(opt.2453D)

SP. 22 MM

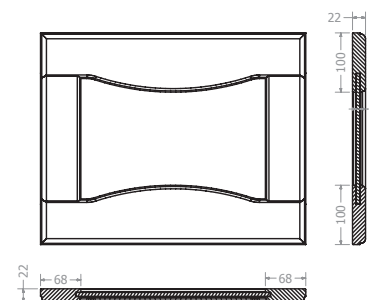

ante vetro in frassino laccate bianche a poro aperto white lacquered ash glass doors open pore



anta vetro satinato bianco inciso lucido con due lati verticali serigrafati (opz.2451S)  
white frosted glass door high-sheen etching on two vertical screenprinted sides (opt.2451S)



anta vetro trasparente serigrafato effetto tessuto con inglesina (opz.2451I)  
fabric-effect screenprinted clear glass door with mullion accents (opt.2451I)



cestone vetro satinato bianco inciso lucido con due lati verticali serigrafati (opz.2451S)  
deep drawers in white frosted glass with high-sheen etching on two vertical screenprinted sides (opt.2451S)



cestone vetro trasparente serigrafato effetto tessuto con inglesina (opz.2451I)  
fabric-effect screenprinted clear glass deep drawer with mullion accents (opt.2451I)

 *colori in pronta consegna  
available colours*

ante vetro in rovere naturale con nodini natural oak with knots glass doors



anta vetro satinato bianco inciso lucido con due lati verticali serigrafati (opz.5501S)  
white frosted glass door high-sheen etching on two vertical screenprinted sides (opt.5501S)



anta vetro trasparente serigrafato effetto tessuto con inglesina (opz.5501I)  
fabric-effect screenprinted clear glass door with mullion accents (opt.5501I)



cestone vetro satinato bianco inciso lucido con due lati verticali serigrafati (opz.5501S)  
deep drawers in white frosted glass with high-sheen etching on two vertical screenprinted sides (opt.5501S)



cestone vetro trasparente serigrafato effetto tessuto con inglesina (opz.5501I)  
fabric-effect screenprinted clear glass deep drawer with mullion accents (opt.5501I)

 *colori in pronta consegna  
available colours*



ante vetro in frassino tinto corda decapè pickled jute ash glass doors



anta vetro satinato bianco inciso lucido con due lati verticali serigrafati (opz.2452S)  
white frosted glass door high-sheen etching on two vertical screenprinted sides (opt.2452S)



anta vetro trasparente serigrafato effetto tessuto con inglesina (opz.2452I)  
fabric-effect screenprinted clear glass door with mullion accents (code 2452I)



cestone vetro satinato bianco inciso lucido con due lati verticali serigrafati (opz.2452S)  
deep drawers in white frosted glass with high-sheen etching on two vertical screenprinted sides (opt.2452S)



cestone vetro trasparente serigrafato effetto tessuto con inglesina (opz.2452I)  
fabric-effect screenprinted clear glass deep drawer with mullion accents (opt.2452I)

ante vetro in frassino tinto noce spazzolato walnut stained brushed ash glass doors



anta vetro satinato bianco inciso lucido con due lati verticali serigrafati (opz.2453S)  
white frosted glass door high-sheen etching on two vertical screenprinted sides (opt.2453S)



anta vetro trasparente serigrafato effetto tessuto con inglesina (opz.2453I)  
fabric-effect screenprinted clear glass door with mullion accents (code 2453I)



cestone vetro satinato bianco inciso lucido con due lati verticali serigrafati (opz.2453S)  
deep drawers in white frosted glass with high-sheen etching on two vertical screenprinted sides (opt.2453S)



cestone vetro trasparente serigrafato effetto tessuto con inglesina (opz.2453I)  
fabric-effect screenprinted clear glass deep drawer with mullion accents (opt.2453I)

SP. 22 MM

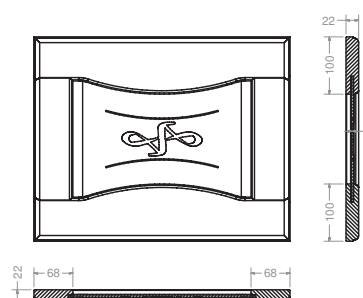

anta vetro satinato bianco  
white frosted glass door

SP. 22 MM

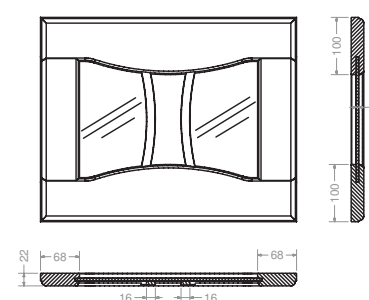

anta vetro con inglesina  
glass door with mullion accents

cod. **K70**

*aurea*

**elementi da 15 con fresata n.b.:**

15 cm elements with groove - Note: for prices see pages 108-109

---



**laccata bianca a poro aperto (opz.2451)**  
white lacquered open pore (opt.2451)



**rovere naturale con nodini (opz.5501)**  
natural oak with knots (opt.5501)



**tinto corda decapè (opz.2452)**  
pickled jute (opt.2452)



**tinto noce spazzolato (opz.2453)**  
walnut stained brushed (opt.2453)



cod. **K70**

*aurea*

## MANIGLIE HANDLES

---

### DI SERIE STANDARD **NEW**



Maniglia 200 finitura argento antico  
passo 128 mm

Handle 200 antique silver finish  
centre-to-centre distance 128 mm



Pomo 200P finitura argento antico  
passo 16 mm

Knob hole 200P antique silver finish  
centre-to-centre distance 16 mm

### A RICHIESTA ON REQUEST **NEW**



Maniglia 240 finitura canna di fucile spazzolato  
passo 160 mm

Handle 240 brushed gunmetal finish  
centre-to-centre distance 160 mm



Pomo 240P finitura canna di fucile spazzolato  
utilizzato per elementi da 15 con maniglia 240

Knob hole 240P brushed gunmetal finish  
used for 15 cm elements with handle 240

### A RICHIESTA ON REQUEST



Maniglia 236 finitura cromo  
passo 128 mm

Handle 236 chrome finish  
centre-to-centre distance 128 mm



Pomo 244P finitura cromo  
utilizzato per elementi da 15 con maniglia 236

Knob hole 244P chrome finish  
used for 15 cm elements with handle 236

### A RICHIESTA ON REQUEST



Maniglia 172 finitura argento vecchio brillante  
passo 96 mm

Handle 172 polished old silver finish  
centre-to-centre distance 96 mm

### A RICHIESTA ON REQUEST



Maniglia 185 finitura ottone  
vecchio chiaro  
passo 96 mm

Handle 185 light old brass finish  
centre-to-centre distance 96 mm

### A RICHIESTA ON REQUEST **NEW**



Maniglia 241 finitura cromo satinato  
passo 64 mm  
passo 160 mm

Handle 241 satin chrome finish  
centre-to-centre distance 64 mm  
centre-to-centre distance 160 mm

## strutture carcasses



bianco camelia (opz.606)  
schiena e ripiano bianco (opz.001)  
camellia white (opt.606)  
white back panel and shelf (opt.001)



corda decapè (opz.566)  
schiena e ripiano bianco (opz.001)  
pickled jute (opt.566)  
white back panel and shelf (opt.001)



castagno tinto noce (opz.582)  
schiena e ripiano bianco (opz.001)  
walnut-stained chestnut (opt.582)  
white back panel and shelf (opt.001)



rovere sbiancato (opz.025)  
schiena e ripiano bianco (opz.001)  
bleached oak (opt.025)  
white back panel and shelf (opt.001)



### CREO ECOLOGIC

IL GRUPPO LUBE HA SCELTO DI UTILIZZARE PER I COMPONENTI COSTITUENTI LE STRUTTURE DELLE CUCINE SOLO MATERIALE A BASSISSIMA EMISSIONE DI FORMALDEIDE: CONFORMI ALLO STANDARD F\*\*\*\* SECONDO LA NORMA JIS, CERTIFICATO DAL MINISTERO GIAPPONESE, IL PIU' SEVERO IN MERITO ALLE NORMATIVE DI SALVAGUARDIA AMBIENTALE.

LUBE GROUP HAS CHOSEN TO EXCLUSIVELY USE MATERIALS WITH VERY LOW FORMALDEHYDE EMISSIONS FOR THE COMPONENTS MAKING UP THE KITCHEN CARCASSES: THESE ELEMENTS COMPLY WITH THE F4 STAR STANDARD ACCORDING TO JIS, CERTIFIED BY THE JAPANESE GOVERNMENT - THE MOST STRINGENT WHEN IT COMES TO ENVIRONMENTAL PROTECTION.

## mensole in laminato laminate shelves



bianco camelia (opz.606)  
camellia white (opt.606)



corda decapè (opz.566)  
pickled jute (opt.566)



castagno tinto noce (opz.582)  
walnut-stained chestnut (opt.582)



rovere sbiancato (opz.025)  
bleached oak (opt.025)

## mensole impiallacciate veneered shelves



impiallacciata come ante  
N.B.: per le finiture vedi colore ante  
veneered same finish as door  
Note: for the finishes see door colours

## zoccoli in pvc H 15 pvc plinths H 15



laccato bianco (opz.569)  
white lacquer (opt.569)



corda decapè (opz.566)  
pickled jute (opt.566)



castagno tinto noce (opz.582)  
walnut-stained chestnut (opt.582)



rovere naturale (opz.620)  
natural oak (opt.620)

## zoccolo in alluminio H 15 aluminium plinth H 15



alluminio liscio finitura brill (opz.412)  
smooth aluminium with brill finish (opt.412)

al ml  
per lm

cod.092155  
code

## cornici cappello top cornices



laccato bianco a poro aperto  
(opz.2451)  
white lacquered open pore  
(opt.2451)



tinto corda decapè (opz.2452)  
stained pickled jute (opt.2452)



tinto noce spazzolato (opz.2453)  
walnut stained brushed (opt.2453)



rovere naturale con nodini  
(opz.5501)  
natural oak with knots (opt.5501)

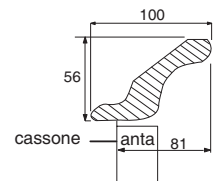

disegno cornice  
design cornice

## top H 4 consigliati in laminato bordo postformato recommended laminate worktops H 4 with post-formed edge

finto marmo bardiglio  
(opz.390) H 4  
fake bardiglio marble  
(opt.390) H 4

travertino (opz.240) H 4  
travertine (opt.240) H 4

finto marmo carrara  
finitura plamky (opz.5540) H 4  
fake carrara marble  
plamky finish (opt.5540) H 4

botticino finitura cliff  
(opz.380) H 4  
botticino with cliff finish  
(opt.380) H 4

calce finitura wraky  
(opz.814) H 4  
white wash with wraky finish  
(opt.814) H 4

quarzo cipria finitura wraky  
(opz.815) H 4  
pale pink quartz with wraky  
finish (opt.815) H 4

sabbia finitura mika  
(opz.823) H 4  
sand with mika finish  
(opt.823) H 4

pietra di nanto finitura wraky  
(opz.812) H 4  
nanto stone with wraky finish  
(opt.812) H 4

finto marmo brown finitura  
plamky (opz.5555) H 4  
fake brown marble with plamky  
finish (opt.5555) H 4

travertino beige con stuccature  
finitura plamky (opz.5548) H 4  
beige travertine with plamky  
plasterings (opt.5548) H 4

oriental finitura plamky  
(opz.5563) H 4  
oriental with plamky  
finish (opt.5563) H 4

dover finitura plamky  
(opz.5567) H 4  
dover with plamky finish  
(opt.5567) H 4

jaipur finitura plamky  
(opz.5564) H 4  
jaipur with plamky finish  
(opt.5564) H 4

## top H 4 consigliati in laminato bordo ABS 1 recommended laminate worktops H 4 with ABS 1 edge

bianco latte finitura wraky  
(opz.813) H 4  
milk white with wraky finish  
(opt.813) H 4

pietra di nanto finitura  
wraky (opz.812) H 4  
nanto stone with wraky finish  
(opt.812) H 4

esterel finitura wraky  
(opz.811) H 4  
esterel with wraky finish  
(opt.811) H 4

beton finitura wraky  
(opz.810) H 4  
beton with wraky finish  
(opt.810) H 4

travertino finitura luna  
(opz.8753) H 4  
travertine with luna finish  
(opt.8753) H 4

dover finitura plamky  
(opz.5567) H 4  
dover with plamky finish  
(opt.5567) H 4

jaipur finitura plamky  
(opz.5564) H 4  
jaipur with plamky finish  
(opt.5564) H 4







# MODULARITÀ E COMPONENTI MODULARITÀ MODULARITY AND FITTING SOLUTIONS

AUREA

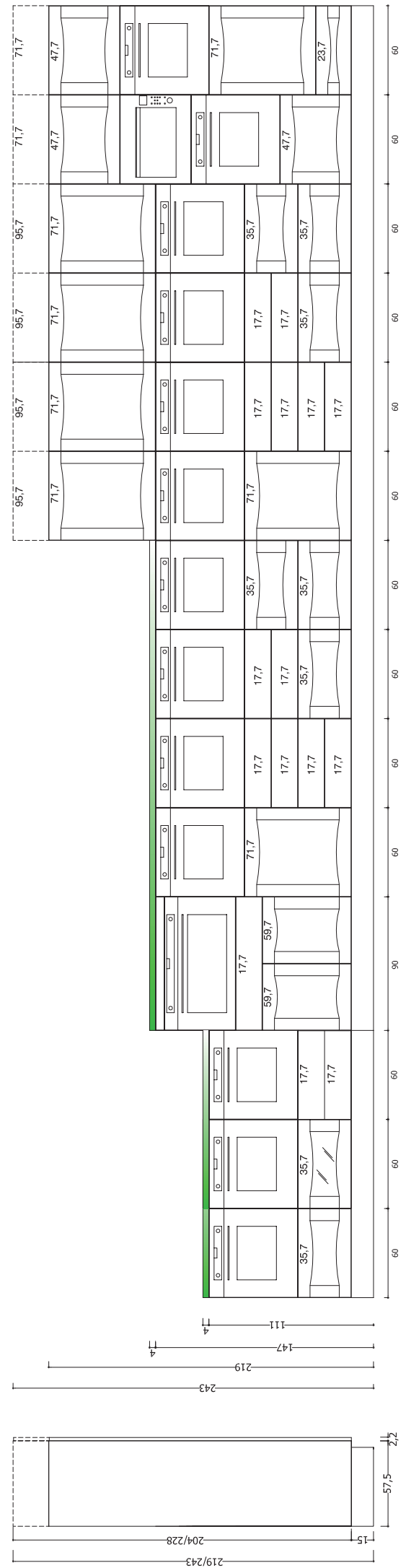
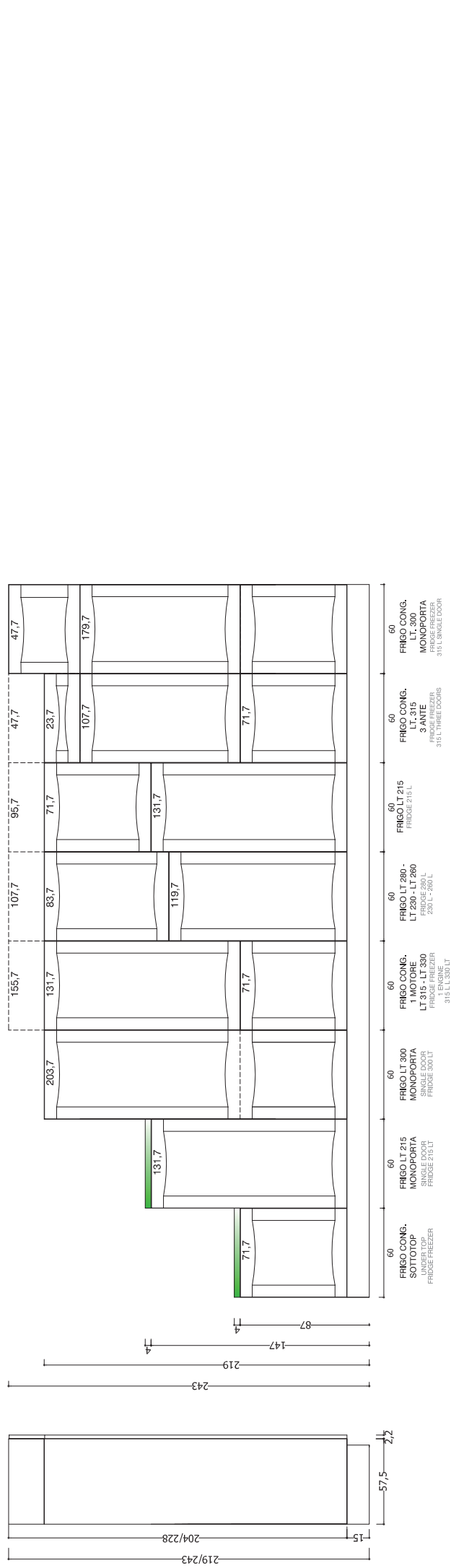





SPESA:  
- olio  
- latte di Soia  
- frotton  
- pane  
R... tanto amore!!

Ho vinto io...  
STASERA LI LAVI TU  
I PIATTI!

TODAY  
\* Buy present  
birthday Anna  
\* Dinner Roberto  
(at the Canal)  
\* cinema 19.00  
DARLING!  
please pick up  
Marco at school ->

2.10  
LATE